

Computational Intelligence

Winter Term 2024/25

Prof. Dr. Günter Rudolph

Computational Intelligence

Fakultät für Informatik

TU Dortmund

- Multi-Layer-Perceptron
 - Model
 - Backpropagation
- Typical Fields of Application
 - Classification
 - Prediction
 - Function Approximation

What can be achieved by adding a layer?

- Single-layer perceptron (SLP)
 - ⇒ Hyperplane separates space in two subspaces
- Two-layer perceptron
 - ⇒ arbitrary convex sets can be separated
- Three-layer perceptron
 - ⇒ arbitrary sets can be partitioned into convex subsets,
convex subsets representable by 2nd layer,
resulting sets can be combined in 3rd layer

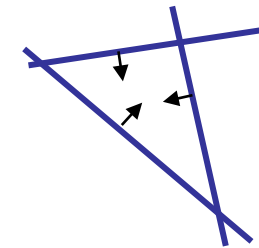
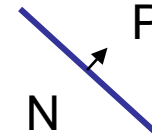

connected by
AND gate in
2nd layer

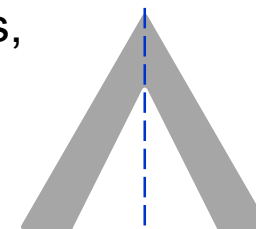

convex sets
of 2nd layer
connected by
OR gate in
3rd layer

⇒ more than 3 layers not necessary (in principle)

XOR with 3 neurons in 2 steps

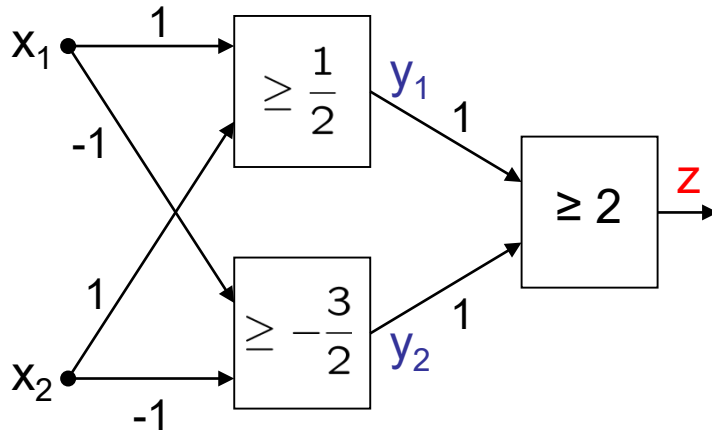

x_1	x_2	y_1	y_2	z
0	0	0	1	0
0	1	1	1	1
1	0	1	1	1
1	1	1	0	0

$$\left. \begin{cases} x_1 + x_2 \geq \frac{1}{2} \\ -x_1 - x_2 \geq -\frac{3}{2} \end{cases} \right\}, \quad \left\{ \begin{cases} x_2 \geq \frac{1}{2} - x_1 \\ x_2 \leq \frac{3}{2} - x_1 \end{cases} \right.$$

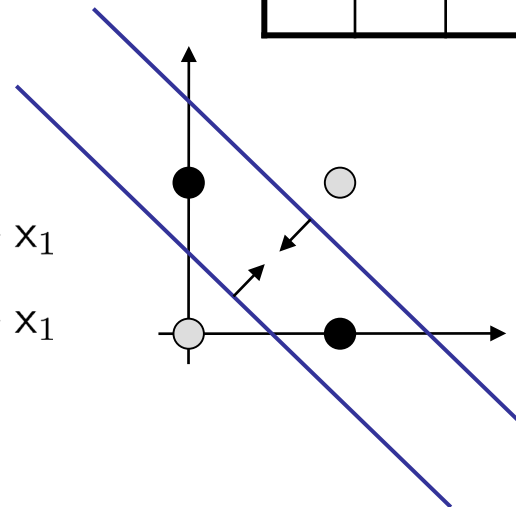

convex set

XOR with 3 neurons in 2 layers

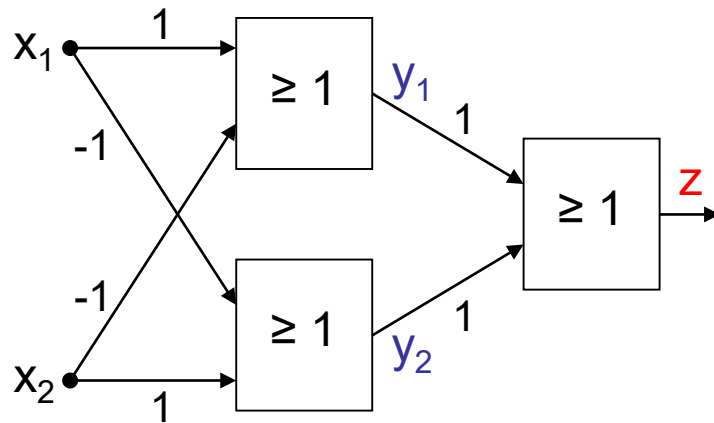

x_1	x_2	y_1	y_2	z
0	0	0	0	0
0	1	0	1	1
1	0	1	0	1
1	1	0	0	0

without AND gate in 2nd layer

$$\left. \begin{array}{l} x_1 - x_2 \geq 1 \\ x_2 - x_1 \geq 1 \end{array} \right\}, \quad \left\{ \begin{array}{l} x_2 \leq x_1 - 1 \\ x_2 \geq x_1 + 1 \end{array} \right.$$

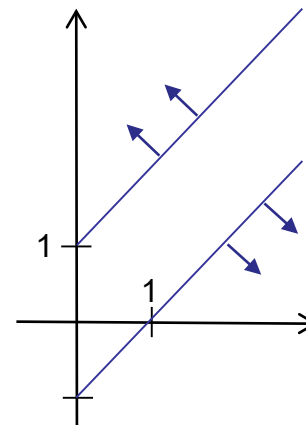

XOR can be realized with only 2 neurons!

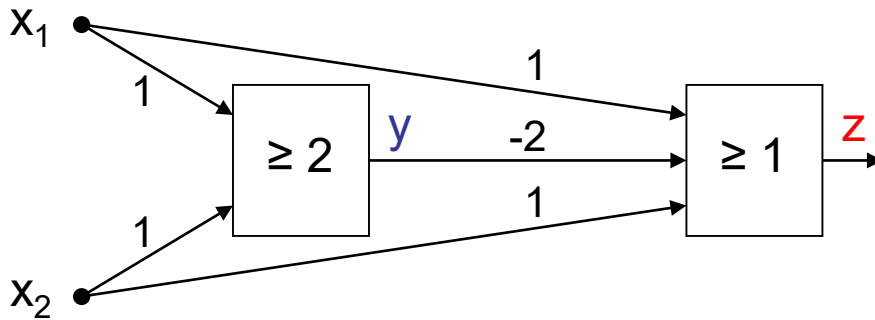

x_1	x_2	y	$-2y$	$x_1 - 2y + x_2$	z
0	0	0	0	0	0
0	1	0	0	1	1
1	0	0	0	1	1
1	1	1	-2	0	0

BUT: this is not a layered network (no MLP) !

Evidently:

MLPs deployable for addressing significantly more difficult problems than SLPs!

But:

How can we adjust all these weights and thresholds?

Is there an efficient learning algorithm for MLPs?

History:

Unavailability of efficient learning algorithm for MLPs was a brake shoe ...

... until **Rumelhart, Hinton and Williams (1986): Backpropagation**

Actually proposed by **Werbos (1974)**

... but unknown to ANN researchers (was PhD thesis)

Quantification of classification error of MLP

- Total Sum Squared Error (TSSE)

$$f(w) = \sum_{x \in B} \underbrace{\|g(w; x)\|}_{\text{output of net for weights } w \text{ and input } x} - \underbrace{g^*(x)}_{\text{target output of net for input } x} \|^2$$

output of net for weights w and input x target output of net for input x

- Total Mean Squared Error (TMSE)

$$f(w) = \frac{1}{|B| \cdot \ell} \sum_{x \in B} \|g(w; x) - g^*(x)\|^2 = \underbrace{\frac{1}{|B| \cdot \ell}}_{\text{const.}} \cdot \text{TSSE}$$

training patterns # output neurons

leads to same solution as TSSE

Learning algorithms for Multi-Layer-Perceptron (here: 2 layers)

idea: minimize error!

$$f(w_t, u_t) = \text{TSSE} \rightarrow \min!$$

Gradient method

$$u_{t+1} = u_t - \gamma \nabla_u f(w_t, u_t)$$

$$w_{t+1} = w_t - \gamma \nabla_w f(w_t, u_t)$$

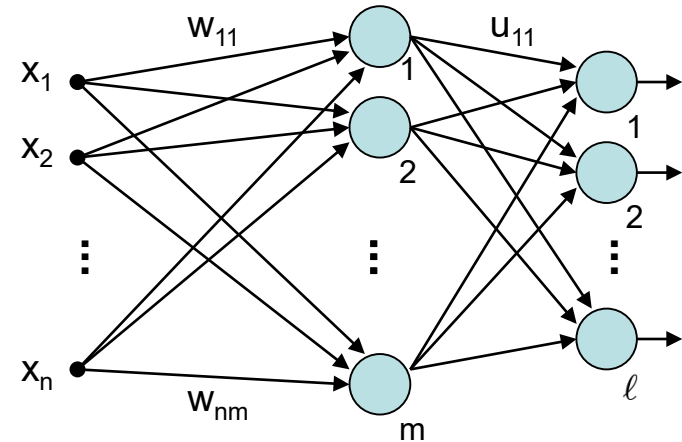

BUT:

$f(w, u)$ cannot be differentiated!

Why? \rightarrow Discontinuous activation function $a(\cdot)$ in neuron!

$$a(x) = \begin{cases} 1 & \text{if } x \geq \theta \\ 0 & \text{otherwise} \end{cases}$$

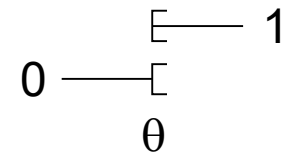

idea: find **smooth** activation function similar to original function !

Learning algorithms for Multi-Layer-Perceptron (here: 2 layers)

good idea: sigmoid activation function (instead of signum function)

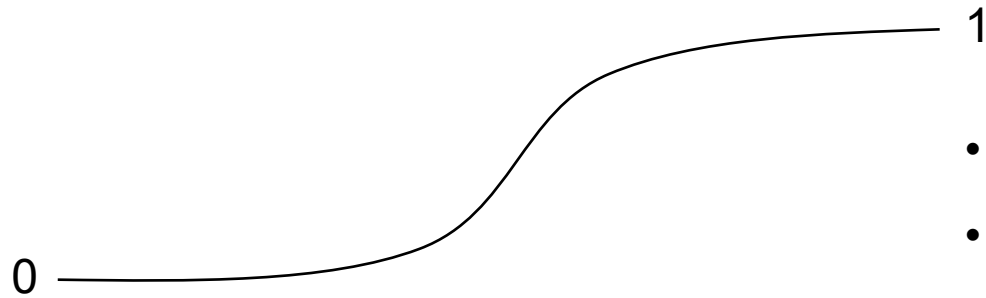
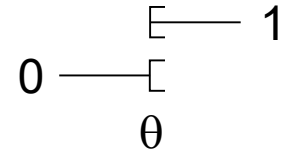

- monotone increasing
- differentiable
- non-linear
- output $\in [0,1]$ instead of $\in \{ 0, 1 \}$
- threshold θ integrated in activation function

e.g.:

$$\bullet \quad a(x) = \frac{1}{1 + e^{-x}} \quad a'(x) = a(x)(1 - a(x))$$

$$\bullet \quad a(x) = \tanh(x) \quad a'(x) = (1 - a^2(x))$$

values of derivatives directly determinable from function values

Learning algorithms for Multi-Layer-Perceptron (here: 2 layers)

Gradient method

$$f(w_t, u_t) = \text{TSSE}$$

$$u_{t+1} = u_t - \gamma \nabla_u f(w_t, u_t)$$

$$w_{t+1} = w_t - \gamma \nabla_w f(w_t, u_t)$$

x_i : inputs

y_j : values after first layer

z_k : values after second layer

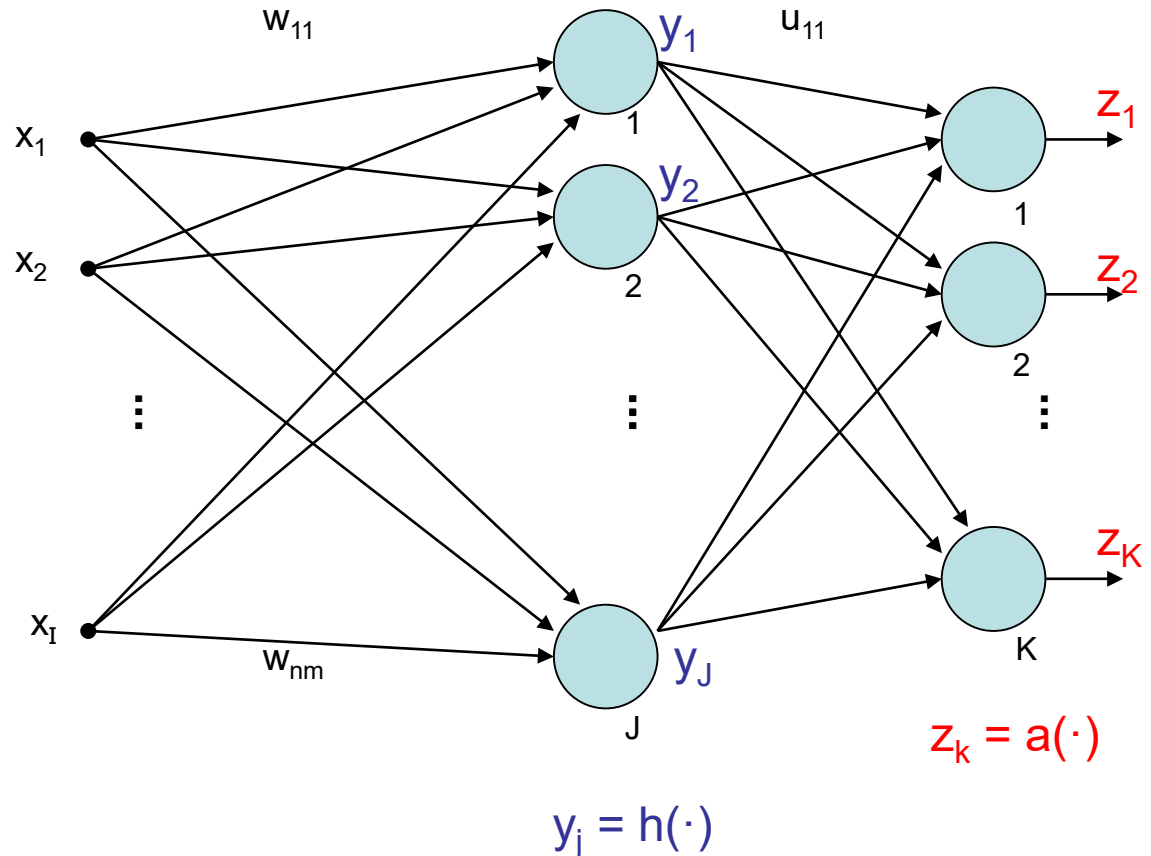

$$y_j = h \left(\sum_{i=1}^I w_{ij} \cdot x_i \right) = h(w'_j x)$$

output of neuron j
after 1st layer

$$z_k = a \left(\sum_{j=1}^J u_{jk} \cdot y_j \right) = a(u'_k y)$$

output of neuron k
after 2nd layer

$$= a \left(\sum_{j=1}^J u_{jk} \cdot h \left(\sum_{i=1}^I w_{ij} \cdot x_i \right) \right)$$

error of input x:

$$f(w, u; x) = \sum_{k=1}^K (z_k(x) - z_k^*(x))^2 = \sum_{k=1}^K (z_k - z_k^*)^2$$

output of net

target output for input x

error for input x and target output z^* :

$$f(w, u; x, z^*) = \sum_{k=1}^K \left[\underbrace{a \left(\sum_{j=1}^J u_{jk} \cdot \underbrace{h \left(\sum_{i=1}^I w_{ij} \cdot x_i \right)}_{y_j} \right)}_{z_k} - z_k^*(x) \right]^2$$

$w'_j x$
 y_j
 z_k

total error for all training patterns $(x, z^*) \in B$:

$$f(w, u) = \sum_{(x, z^*) \in B} f(w, u; x, z^*) \quad (\text{TSSE})$$

gradient of total error:

$$\nabla f(w, u) = \sum_{(x, z^*) \in B} \nabla f(w, u; x, z^*)$$

vector of partial derivatives w.r.t. weights u_{jk} and w_{ij}

thus:

$$\frac{\partial f(w, u)}{\partial u_{jk}} = \sum_{(x, z^*) \in B} \frac{\partial f(w, u; x, z^*)}{\partial u_{jk}}$$

and

$$\frac{\partial f(w, u)}{\partial w_{ij}} = \sum_{(x, z^*) \in B} \frac{\partial f(w, u; x, z^*)}{\partial w_{ij}}$$

assume: $a(x) = \frac{1}{1 + e^{-x}} \Rightarrow \frac{d a(x)}{d x} = a'(x) = a(x) \cdot (1 - a(x))$

and: $h(x) = a(x)$

chain rule of differential calculus:

$$[p(q(x))]' = \underbrace{p'(q(x))}_{\text{outer derivative}} \cdot \underbrace{q'(x)}_{\text{inner derivative}}$$

$$f(w, u; x, z^*) = \sum_{k=1}^K [a(u'_k y) - z_k^*]^2$$

partial derivative w.r.t. u_{jk} :

$$\begin{aligned} \frac{\partial f(w, u; x, z^*)}{\partial u_{jk}} &= 2 [a(u'_k y) - z_k^*] \cdot a'(u'_k y) \cdot y_j \\ &= 2 [a(u'_k y) - z_k^*] \cdot a(u'_k y) \cdot (1 - a(u'_k y)) \cdot y_j \\ &= 2 \underbrace{[z_k - z_k^*] \cdot z_k \cdot (1 - z_k)}_{\text{"error signal"} \delta_k} \cdot y_j \end{aligned}$$

partial derivative w.r.t. w_{ij} :

$$\begin{aligned}
 \frac{\partial f(w, u; x, z^*)}{\partial w_{ij}} &= 2 \sum_{k=1}^K \underbrace{[a(u'_k y) - z_k^*]}_{z_k} \cdot \underbrace{a'(u'_k y)}_{z_k(1-z_k)} \cdot u_{jk} \cdot \underbrace{h'(w'_j x)}_{y_j(1-y_j)} \cdot x_i \\
 &= 2 \cdot \sum_{k=1}^K [z_k - z_k^*] \cdot z_k \cdot (1 - z_k) \cdot u_{jk} \cdot y_j (1 - y_j) \cdot x_i \\
 &\stackrel{\text{factors reordered}}{=} x_i \cdot y_j \cdot (1 - y_j) \cdot \underbrace{\sum_{k=1}^K 2 \cdot [z_k - z_k^*] \cdot z_k \cdot (1 - z_k) \cdot u_{jk}}_{\text{error signal } \delta_k \text{ from previous layer}} \\
 &\quad \underbrace{\hspace{15em}}_{\text{error signal } \delta_j \text{ from "current" layer}}
 \end{aligned}$$

Generalization (> 2 layers)

Let neural network have L layers S_1, S_2, \dots, S_L .

Let neurons of all layers be numbered from 1 to N.

} $j \in S_m \rightarrow$
neuron j is in
m-th layer

All weights w_{ij} are gathered in weights matrix W.

Let o_j be output of neuron j.

error signal:

$$\delta_j = \begin{cases} o_j \cdot (1 - o_j) \cdot (o_j - z_j^*) & \text{if } j \in S_L \text{ (output neuron)} \\ o_j \cdot (1 - o_j) \cdot \sum_{k \in S_{m+1}} \delta_k \cdot w_{jk} & \text{if } j \in S_m \text{ and } m < L \end{cases}$$

correction:

$$w_{ij}^{(t+1)} = w_{ij}^{(t)} - \gamma \cdot o_i \cdot \delta_j$$

in case of online learning:

correction after **each** test pattern presented

error signal of neuron in inner layer determined by

- error signals of all neurons of subsequent layer and
- weights of associated connections.



- First determine error signals of output neurons,
- use these error signals to calculate the error signals of the preceding layer,
- use these error signals to calculate the error signals of the preceding layer,
- and so forth until reaching the first inner layer.



thus, error is propagated backwards from output layer to first inner layer
⇒ **backpropagation** (of error)

⇒ other optimization algorithms deployable!

in addition to **backpropagation** (gradient descent) also:

- **Backpropagation with Momentum**

take into account also previous change of weights:

$$\Delta w_{ij}^{(t)} = -\gamma_1 \cdot o_i \cdot \delta_j - \gamma_2 \cdot \Delta w_{ij}^{(t-1)}$$

- **QuickProp**

assumption: error function can be approximated locally by quadratic function,
update rule uses last two weights at step $t - 1$ and $t - 2$.

- **Resilient Propagation (RPROP)**

exploits sign of partial derivatives:

2 times negative or positive → increase step size!

change of sign → reset last step and decrease step size!

typical values: factor for decreasing 0,5 / factor for increasing 1,2

- **Evolutionary Algorithms**

individual = weights matrix

Classification

given: set of training patterns (input / output)

output = label
(e.g. class A, class B, ...)

\tilde{x}_i \tilde{y}_i

parameters

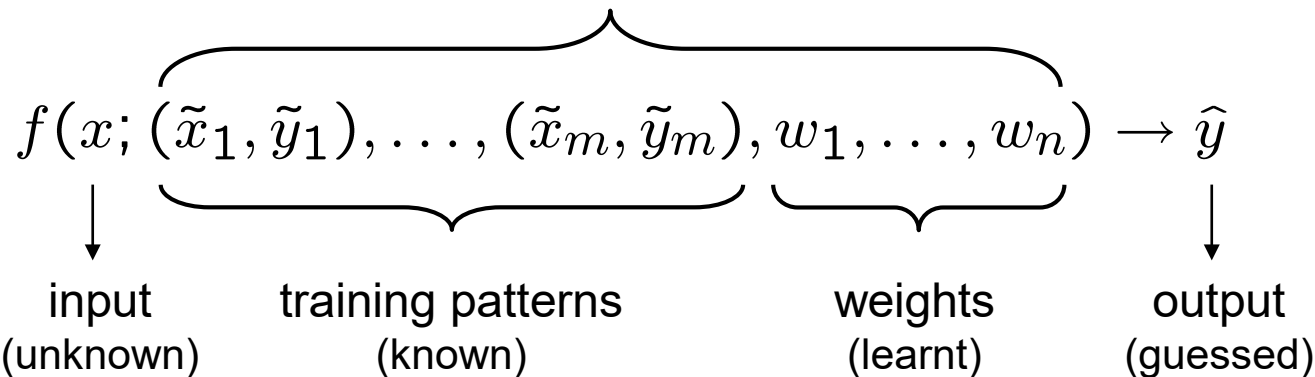

phase I:

train network

phase II:

apply network to unknown inputs for classification

Prediction of Time Series

time series x_1, x_2, x_3, \dots (e.g. temperatures, exchange rates, ...)

task: given a subset of historical data, predict the future

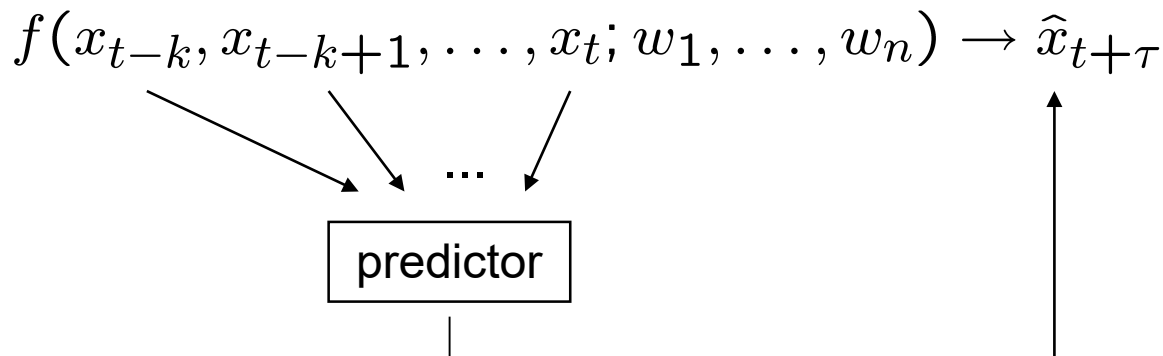

training patterns:

historical data where true output is known;

error per pattern = $(\hat{x}_{t+\tau} - x_{t+\tau})^2$

phase I:

train network

phase II:

apply network
to historical
inputs for
predicting
unkown
outputs

Prediction of Time Series: Example for Creating Training Data

given: time series 10.5, 3.4, 5.6, 2.4, 5.9, 8.4, 3.9, 4.4, 1.7

time window: $k=3$

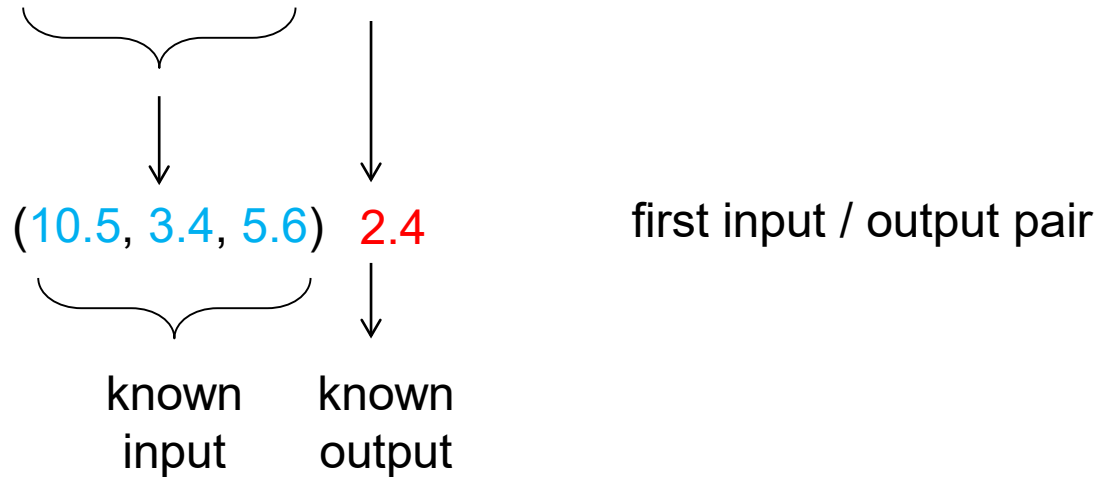

further input / output pairs:

$(3.4, 5.6, 2.4)$	5.9
$(5.6, 2.4, 5.9)$	8.4
$(2.4, 5.9, 8.4)$	3.9
$(5.9, 8.4, 3.9)$	4.4
$(8.4, 3.9, 4.4)$	1.7

Function Approximation (the general case)

task: given training patterns (input / output), approximate unknown function

→ should give outputs close to true unknown function for arbitrary inputs

- values between training patterns are **interpolated**
- values outside convex hull of training patterns are **extrapolated**

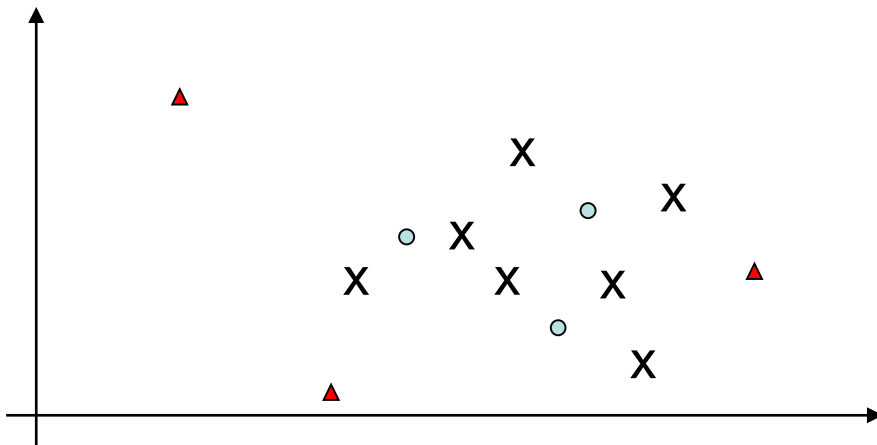

x : input training pattern

o : input pattern where output to be interpolated

▲ : input pattern where output to be extrapolated